

POT & BAG TRANSPORTABLE FILLER



Williames

Leading by Innovation



**MOVE POT & BAG FILLER BETWEEN
MULTIPLE SITES FOR MULTIPLE
ACTIVITIES (Greg Brens, Senior Draftsman)**

Williames Pty Limited
A B N 42 004 320 834
103 Butlers Track Warragul
Victoria 3820 Australia
phone: +61 3 5623 5755
fax: +61 3 5623 5165
email: sales@whiti.com.au
web: www.williames.com

POT & BAG TRANSPORTABLE FILLER



Williames

Leading by Innovation



Williames Transportable Pot & Bag Filler is a customised design to meet the requirements for large scale commercial pot filling.

It delivers a high degree of flexibility to move between production facilities and can be pulled by tractor between sites, or different places of production and growth.

Features

- Creates greater operational flexibility when used at multiple locations, or for different potting purposes
- Two heads allow two bags or pots to be filled simultaneously



- Easily controlled with foot pedal
- Variable conveyor speed to control speed of soil delivery
- The Bin can be emptied through the back without running the soil or other growth medium through the machine which also gives easy access for cleaning or for quickly changing the soil/medium mix

TRANSPORTABLE POT & BAG FILLER ON TRAILER WITH DUAL WHEELS

Williames Pty Limited
A B N 42 004 320 834
103 Butlers Track Warragul
Victoria 3820 Australia
phone: +61 3 5623 5755
fax: +61 3 5623 5165
email: sales@whiti.com.au
web: www.williames.com

POT & BAG TRANSPORTABLE FILLER



Williames

Leading by Innovation



← **UNIVERSAL FILLER WITH ONE OR MULTIPLE SOIL FEED CONVEYORS** is suited to the high speed filling of a wide range of pot sizes. It includes:

- Variable speed drive for precisely controlled filling speed
- Integrated soil return units recycle soil mix to prevent wastage and soil contamination
- Safe operation with emergency STOP / START control and mesh guarding
- 1.8 cubic metre capacity
- Robust constructions means low maintenance, low downtime, high reliability and productivity



ABOVE: Transportable Pot Filler

DIMENSIONS

TRANSPORTABLE TWIN POT & BAG FILLER

	METRIC	IMPERIAL
Length	27.890	91' 06"
Width	4.245	13' 11"
Height	3.010	9' 10"
Weight	4,825 kgs	10,615 lbs



← **TRANSFER CONVEYOR** moves the soil from the top of the Universal Filler to the Soil Feed Shutes

- Robust constructions means low maintenance, low downtime, high reliability and productivity



← **GALVANISED ROLLER CONVEYOR**

- Simple to operate.
- Trays trip the automatic START / STOP activation.
- Adjustable feed-gate.
- Robust constructions means low maintenance, low downtime, high reliability and productivity

Williames Pty Limited
A B N 42 004 320 834
103 Butlers Track Warragul
Victoria 3820 Australia
phone: +61 3 5623 5755
fax: +61 3 5623 5165
email: sales@whiti.com.au
web: www.williames.com

POT & BAG TRANSPORTABLE FILLER



Williames

Leading by Innovation

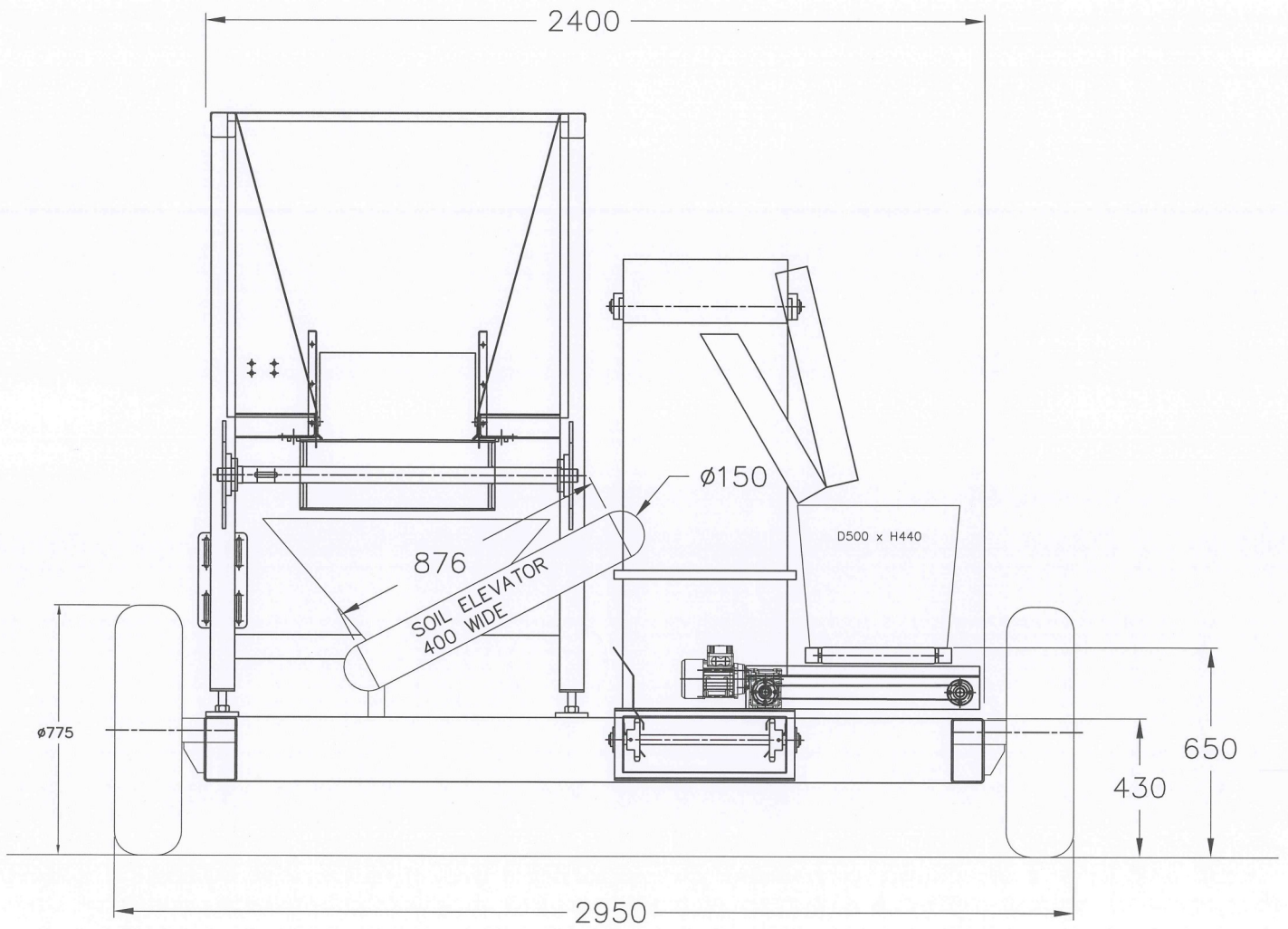

POT & BAG TRANSPORTABLE FILLER



Williames

Leading by Innovation

